



## Heat and cold meter Q heat 5.5 US R

### Static ultrasonic heat and cold meter

- › Precise and durable ultrasonic measurement technology
- › Flow sensor in all-metal design with nominal flow rate  $q_p$  0.6-10 m<sup>3</sup>/h
- › Integrated radio technology for integration into a Q walk-by or Q AMR system
- › Flexibility by changing the return and supply flow as well as the energy unit
- › Heat meter, heat meter with cooling option and cold meter
- › Short and static temperature measurement cycle
- › Compact design and detachable calculator unit
- › Any installation position without restrictions

## Application

The measuring device is used to record heat energy or cold energy. The main areas of application are supply systems with a central heating or cooling circuit in which only water is used as the energy medium.

## Features

- › Flow sensor in all-metal design with nominal flow  $Q_p$  0.6 m<sup>3</sup>/h ... 10. m<sup>3</sup>/h
- › patented, contamination-resistant ultrasonic measurement process
- › position-independent, high dynamic range up for detection of smallest flow rates
- › Radio data transmission by sending Q AMR- and Q walk-by telegrams in C-mode as standard
- › Optional only with Q AMR telegrams or Q AMR extended telegrams<sup>1</sup> available for system optimization
- › For secure data transmission optionally with AES encryption mode 5 and mode 7 available
- › Flexibility during commissioning by switching the return and supply flow without exchanging the temperature sensors as well as changing the energy unit
- › Available as heat meter, heat meter with cooling option and cold meter
- › Standard ort and static temperature measurement cycle every 12 seconds (with 10 year battery) - ideal for use in central supply facilities
- › Compact design and detachable calculator unit as standard for tight and difficult-to-access installation situations
- › any installation position, also „overhead“

## Technical data

General	
	<p>QUNDIS GmbH hereby declares that the heat meter with ultrasonic Q heat 5.5 US R complies with directives 2014/53/EU (RED), 2011/65/EU (RoHS) and 2014/32/EU (MID).</p> <p>The full text of the EU Declaration of Conformity is available at the following Internet address: <a href="https://qundis.com/service/downloads-and-information/eu-declaration-of-conformity/#qr01">https://qundis.com/service/downloads-and-information/eu-declaration-of-conformity/#qr01</a></p>
Ambient conditions	
Protection rating	Calculator unit: IP65 according to EN 60529 Flow sensor: IP65 according to EN 60529
Transport	-25 °C ... 70 °C, < 95 % r.F. (without condensation)
Storage	-5 °C ... 45 °C, < 95 % r.F. (without condensation)
Usage	5 °C ... 55 °C, < 95 % r.F. (without condensation)
Medium	Only use water without chemical additives as the medium for this device. Glycol additives or sodium chloride NaCl (common salt) are expressly not permissible.
Standards	
Interference resistance and interference emission	EN 301 489-1, EN 301 489-3
Security	EN 62368-1 , EN 62479
Quality of the heating medium	according to VDI guideline 2035, AGFW standard 510
Influencing quantities	
Electromagnetic class	E1

<sup>1</sup> Q AMR telegram extended by current flow temperature, current return temperature, current volume flow and current output

Influencing quantities	
Mechanical class	M2
Ambient class	A
Measuring accuracy class	3/2 (depending on flow sensor)
Calculator unit Temperature range	
as heat meter	0 °C ... 105 °C
as heat meter with cooling option <sup>2</sup>	0 °C ... 105 °C
as cold meter <sup>3</sup>	0 °C ... 50 °C
Calculator unit Temperature difference range	
as heat meter	3 K ... 70 K
as heat meter with cooling option	3 K ... 70 K
as cold meter	3 K ... 50 K
start of metering temperature difference	0.2 K
Power supply	
Lithium battery	Nominal voltage 3.0 V
Lithium content	0.86 g
Battery type	CR17450E-R
Batteries per device	1 (not replaceable)
Battery life	7 (optional 10) years
Display levels	
Display	8-digit LCD + pictograms
Display consumption value	kWh - MWh MJ - GJ kWh - MJ (only up to 50 litres cumulative flow rate) MWh - GJ (only up to 50 litres cumulative flow rate)
Cable length Calculator unit - Flow sensor	
Cable length	80 cm

<sup>2</sup> Cold register not assessed for conformity. National regulations must be observed.

<sup>3</sup> Cold register conformity-assessed according to Technical Guideline K 7.2. PTB (Germany). Observe national regulations!

## Technical data Communication

Radio technology	
Radio mode	C-Mode (Q AMR, Q walk-by)
Radio frequency	EN 300 220-2 C-Mode (868.95 +/- 0.25) MHz
Transmission power	C-Mode (max. 14 dBm / typ. 10 dBm)
Encryption <sup>4</sup>	Security Mode 5 and 7 according to EN 13757-7, Security Profile A and B according to OMS specification
Duty cycle	< 0.1 % (50 ms/128 s)
Data transmission	EN 13757-4

## Technical data Temperature sensor

Temperature sensor	
Measuring element	Pt1000 according to EN 60751
Version	Type DS
Diameter Ø	5.0 mm - 5.2 mm - 6.0 mm - AGFW
Installation variant <sup>5</sup>	5.0 mm - direct (Ball valve) / indirect (Immersion sleeve) 5.2 mm - direct (Ball valve) / indirect (Immersion sleeve) 6.0 mm - direct (Ball valve) / indirect (Immersion sleeve) AGFW 27.5 mm - direct (Ball valve) AGFW 38 mm ( $\geq q_p$ 3.5 m <sup>3</sup> ) - direct (Ball valve)
Cable length	Standard: 1.5 m Optional: 3.0 m

<sup>4</sup> Encryption optional

<sup>5</sup> Observe national and country-specific regulations on the use of immersion sleeves!

## Technical data Flow sensor

Nominal flow rate $q_p$	0.6 m <sup>3</sup> /h	1.5 m <sup>3</sup> /h	1.5 m <sup>3</sup> /h	2.5 m <sup>3</sup> /h
Nominal diameter DN	15 mm	15 mm	20 mm	20 mm
Overall length	110 mm	110 mm	130 mm	130 mm
Connection	G 3/4 B	G 3/4 B	G 1 B	G 1 B
Weight	530 g	530 g	660 g	660 g
Installation location	Return flow or supply flow (switchable up to 50 litres cumulative flow)			
Installation position	any			
Inflow and outflow zone	not required (U0/D0)			
Minimum flow $q_i$	12 l/h	15 l/h	30 l/h	25 l/h
Maximum flow $q_s$	1200 l/h	3000 l/h	3000 l/h	5000 l/h
Start-up limit $q_0$	6 l/h	6 l/h	10 l/h	10 l/h
Dynamic range	1:50	1:100	1:50	1:100
Measuring accuracy class	3	2	3	2
Pressure loss at $q_p$	20 mbar	130 mbar	65 mbar	180 mbar
Max. permissible operating pressure	16 bar			
Min. system pressure to avoid cavitation <sup>6</sup>	1 bar	1.5 bar	1 bar	2 bar
Temperature range as heat meter	5 °C ... 90 °C			
Temperature range as heat meter with cooling option	5 °C ... 90 °C			
Temperature range as cold meter	5 °C ... 50 °C			

<sup>6</sup> cavity formation in fast flowing liquids

Nominal flow rate $q_p$	3.5 m <sup>3</sup> /h	3.5 m <sup>3</sup> /h	6.0 m <sup>3</sup> /h	6.0 m <sup>3</sup> /h	10.0 m <sup>3</sup> /h	10.0 m <sup>3</sup> /h
Nominal diameter DN	25 mm	25 mm	25 mm	25 mm	40 mm	40 mm
Overall length	150 mm	260 mm	150 mm	260 mm	200 mm	300 mm
Connection	G 1 1/4 B	G 1 1/4 B	G 1 1/4 B	G 1 1/4 B	G 2 B	G 2 B
Weight	875 g	1173 g	875 g	1173 g	1390 g	1750 g
Installation location	Return flow or supply flow (switchable up to 50 litres cumulative flow)					
Installation position	any					
Inflow and outflow zone	not required (U0/D0)					
Minimum flow $q_l$ (optionally available)	28 l/h	28 l/h	48 l/h (24 l/h)	48 l/h (24 l/h)	100 l/h	100 l/h
Maximum flow $q_s$	7000 l/h	7000 l/h	12000 l/h	12000 l/h	20000 l/h	20000 l/h
Start-up limit $q_0$ (optionally available)	14 l/h	14 l/h	24 l/h (12 l/h)	24 l/h (12 l/h)	50 l/h	50 l/h
Dynamic range (optionally available)	1:125	1:125	1:125 (1:250)	1:125 (1:250)	1:100	1:100
Measuring accuracy class	2	2	2	2	2	2
Pressure loss at $q_p$	49 mbar	38 mbar	152 mbar	122 mbar	169 mbar	168 mbar
Max. permissible operating pressure	16 bar					
Min. system pressure to avoid cavitation <sup>7</sup>	1 bar	1 bar	1.5 bar	1.5 bar	1.5 bar	1.5 bar
Temperature range as heat meter	5 °C ... 90 °C					
Temperature range as heat meter with cooling option	5 °C ... 90 °C					
Temperature range as cold meter	5 °C ... 50 °C					

<sup>7</sup> cavity formation in fast flowing liquids

## Dimensional drawings

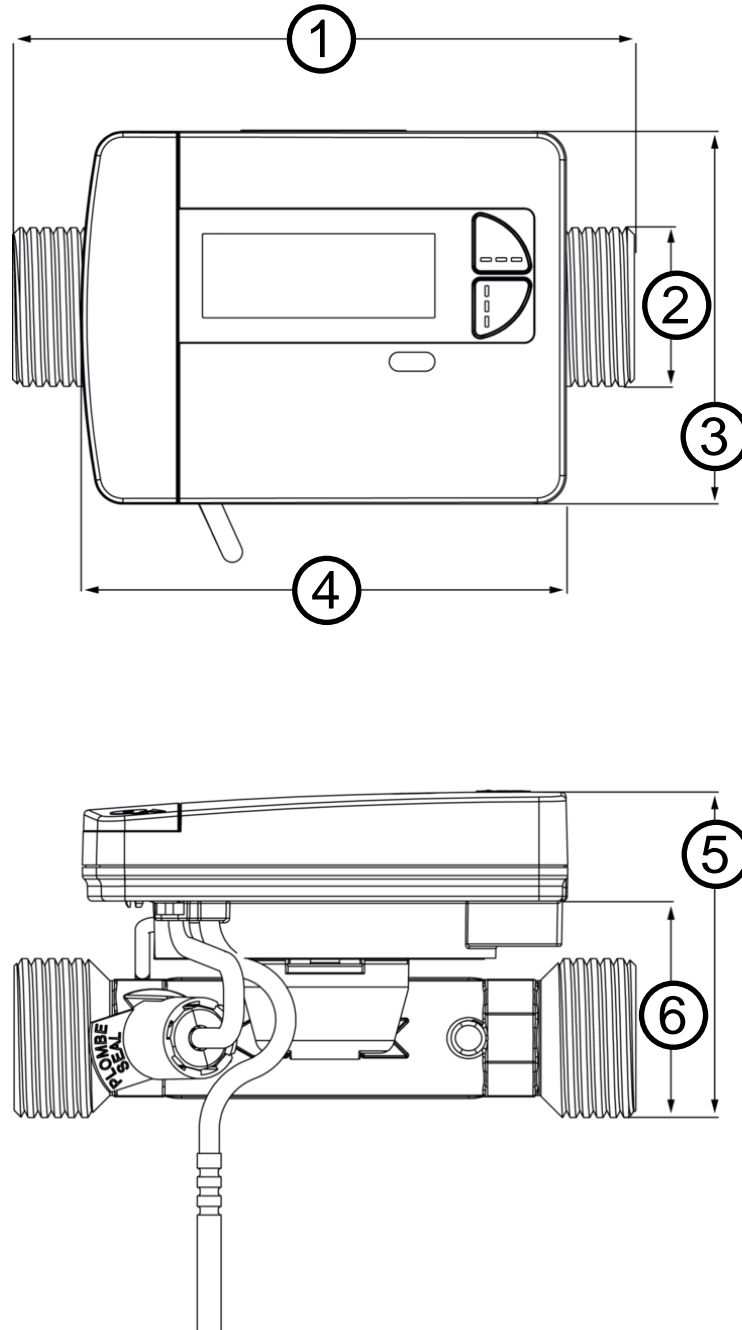

	0.6 m³/h	1.5 m³/h	1.5 m³/h	2.5 m³/h	3.5 m³/h	3.5 m³/h	6.0 m³/h	6.0 m³/h	10,0 m³/h	10,0 m³/h
<b>1</b>	110 mm	110 mm	130 mm	130 mm	150 mm	260 mm	150 mm	260 mm	200 mm	300 mm
<b>2</b>	G 3/4 B	G 3/4 B	G 1 B	G 1 B	G 1 1/4 B	G 1 1/4 B	G 1 1/4 B	G 1 1/4 B	G 2 B	G 2 B
<b>3</b>	78 mm									
<b>4</b>	101.5 mm									
<b>5</b>	65 mm	65 mm	68.48 mm	68.48 mm	84 mm	84 mm	84 mm	84 mm	100 mm	100 mm
<b>6</b>	41.5 mm	41.5 mm	45 mm	45 mm	60.5 mm	60.5 mm	60.5 mm	60.5 mm	76.5 mm	76.5 mm



**QUNDIS GmbH**

Sonnentor 2  
99098 Erfurt  
Germany  
Phone.: +49 (0) 361 26 280-0  
Fax: +49 (0) 361 26 280-175  
E mail: info@qundis.com

**www.qundis.com**

A company of the  
**noventic group**

The information in this data sheet only contains general descriptions or product characteristics, which may not always apply in particular application cases and/or may be subject to change through further development of the product. Required product characteristics are then binding if they are expressly agreed when the contract is drawn up.  
©2025 QUNDIS GmbH. Subject to change.